

U17BS

Rank	Seed	Name	Country	Score
1	*seed 1	JUNG Suk Hoon (ジュン スックフン) (KOR)		
2		SASAKI Takashi (佐々木 崇) (JPN)	1	JUNG (21-6) (21-12)
3		PHETPRADAB Khosit (เฟ็ตปราดะบ ฮอร์ชิต) (THA)	9	PHETPRADAB (22-20) (21-13)
4	Q2	KONDO Takumi (近藤 拓未) (JPN)	2	PHETPRADAB (26-24) (21-15)
5		PARK Dae Woong (パク デウン) (KOR)	13	PHETPRADAB (21-14) (21-19)
6		INOUE Takuto (井上 拓斗) (JPN)	3	INOUE (21-17) (27-25)
7		HOTTA Shugo (堀田 周吾) (JPN)	10	INOUE (16-21) (21-11) (21-12)
8		LI Kuei Yi (リー クエイイー) (TPE)	4	HOTTA (21-14) (24-22)
9	Q4	KOGA Akira (古賀 輝) (JPN)	15	PHETPRADAB (21-16) (21-16)
10		TONG Chi Long (トン チーロン) (HKG)	5	KOGA (21-9) (21-19)
11		LEE Hong Je (イ ホンジェ) (KOR)	11	LEE (21-19) (21-12)
12	Q3	KANEKO Yuki (金子 祐樹) (JPN)	6	LEE (19-21) (22-20) (21-18)
13		JUN Bong Chan (ジュン ボンチャン) (KOR)	14	LEE (21-11) (21-12)
14	Q1	SAKURAI Keisuke (櫻井 恵介) (JPN)	7	SAKURAI (22-20) (17-21) (21-14)
15		TSAI Jia You (ツァイ ジアユー) (TPE)	12	TOYOSHIMA (21-7) (16-21) (21-17)
16	*seed 2	TOYOSHIMA Daichi (豊島 大地) (JPN)	8	TOYOSHIMA (21-5) (21-12)

U17GS

Rank	Seed	Country	Player Name	Player Name (Kana)	Player Name (Roman)	Country
1	*seed 1	(KOR)	KANG	Ga Hee	ガヒー	(KOR)
2	WDN	(JPN)	WATANABE	Akane	あかね	(JPN)
3		(JPN)	HAYAKAWA	Saori	紗保里	(JPN)
4	PFQ	(JPN)	FUKUNAGA	Aya	彩	(JPN)
5	Q2	(JPN)	MIKI	Eriko	江里子	(JPN)
6		(HKG)	CHANG	Lap Yi	ラッピー	(HKG)
7		(JPN)	TAKASE	Hideho	秀穂	(JPN)
8		(KOR)	YANG	Soo Youn	スーヨン	(KOR)
9	Q3	(JPN)	SHINOYA	Naru	菜留	(JPN)
10		(KOR)	LEE	So Hee	ソヒー	(KOR)
11		(JPN)	KIMURA	Momoka	百花	(JPN)
12	Q1	(JPN)	HAMASAKI	Mai	真衣	(JPN)
13		(KOR)	PARK	So Young	ソヨン	(KOR)
14		(HKG)	YUEN	Sin Ying	シンイン	(HKG)
15	Q4	(KOR)	KIM	Ji Won	ジウオン	(KOR)
16	*seed 2	(JPN)	OKUHARA	Nozomi	希望	(JPN)

Round	Match	Winner	Score
1	1 vs 2	KANG	W/O
2	3 vs 4	HAYAKAWA	(21-15) (21-13)
3	5 vs 6	MIKI	(21-9) (21-14)
4	7 vs 8	TAKASE	(21-17) (21-18)
5	9 vs 10	LEE	(21-14) (21-16)
6	11 vs 12	HAMASAKI	(15-21) (21-18) (21-13)
7	13 vs 14	PARK	(21-14) (22-20)
8	15 vs 16	OKUHARA	(21-15) (21-5)
9	1 vs 3	KANG	(21-16) (21-14)
10	2 vs 4	MIKI	(13-21) (21-16) (21-15)
11	5 vs 7	LEE	(21-13) (21-13)
12	6 vs 8	OKUHARA	(21-13) (21-7)
13	9 vs 11	KANG	(21-19) (16-21) (21-17)
14	10 vs 12	LEE	(21-17) (23-21)
15	13 vs 14	LEE	(21-19) (21-19)

U17BD

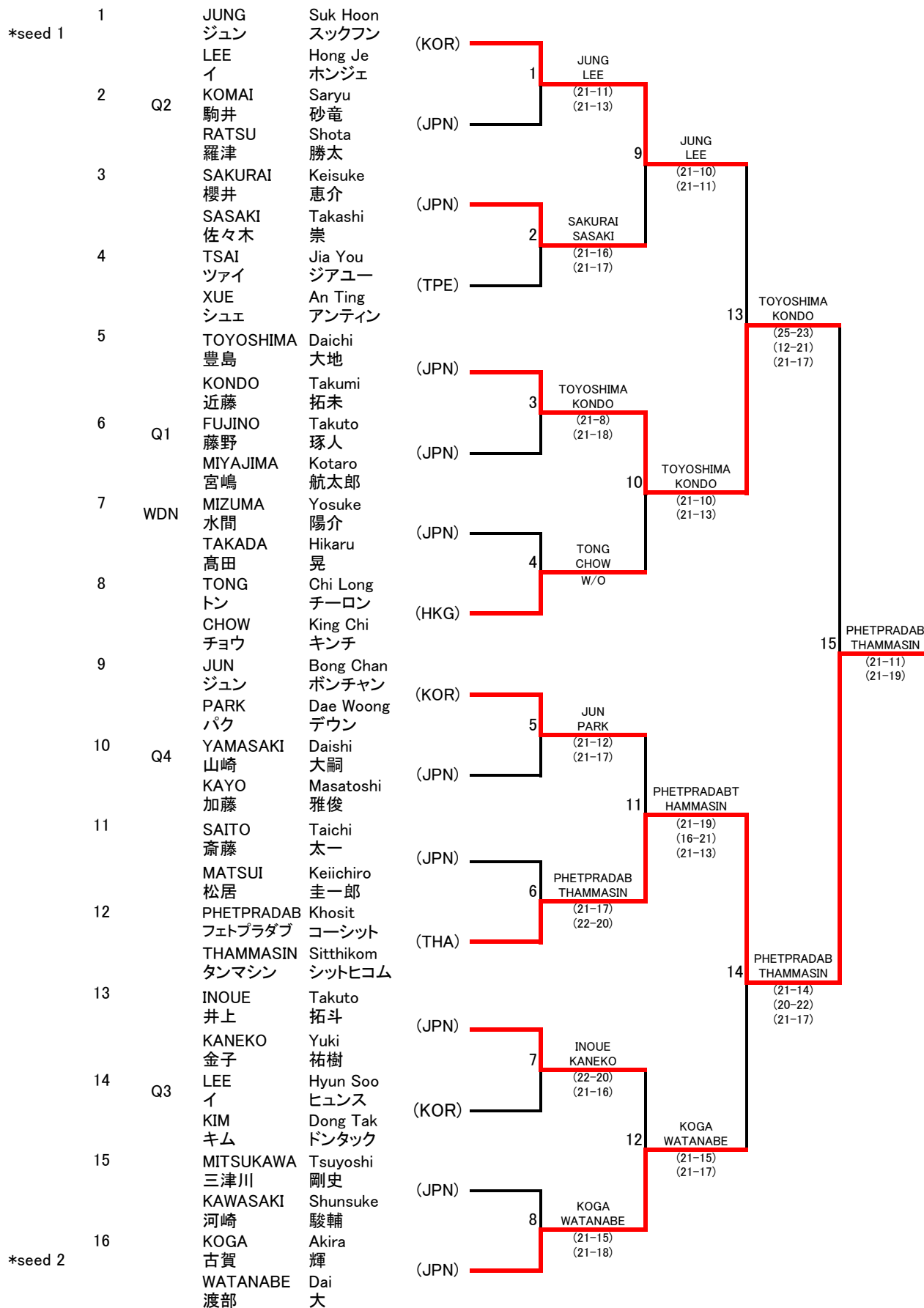

U17GD

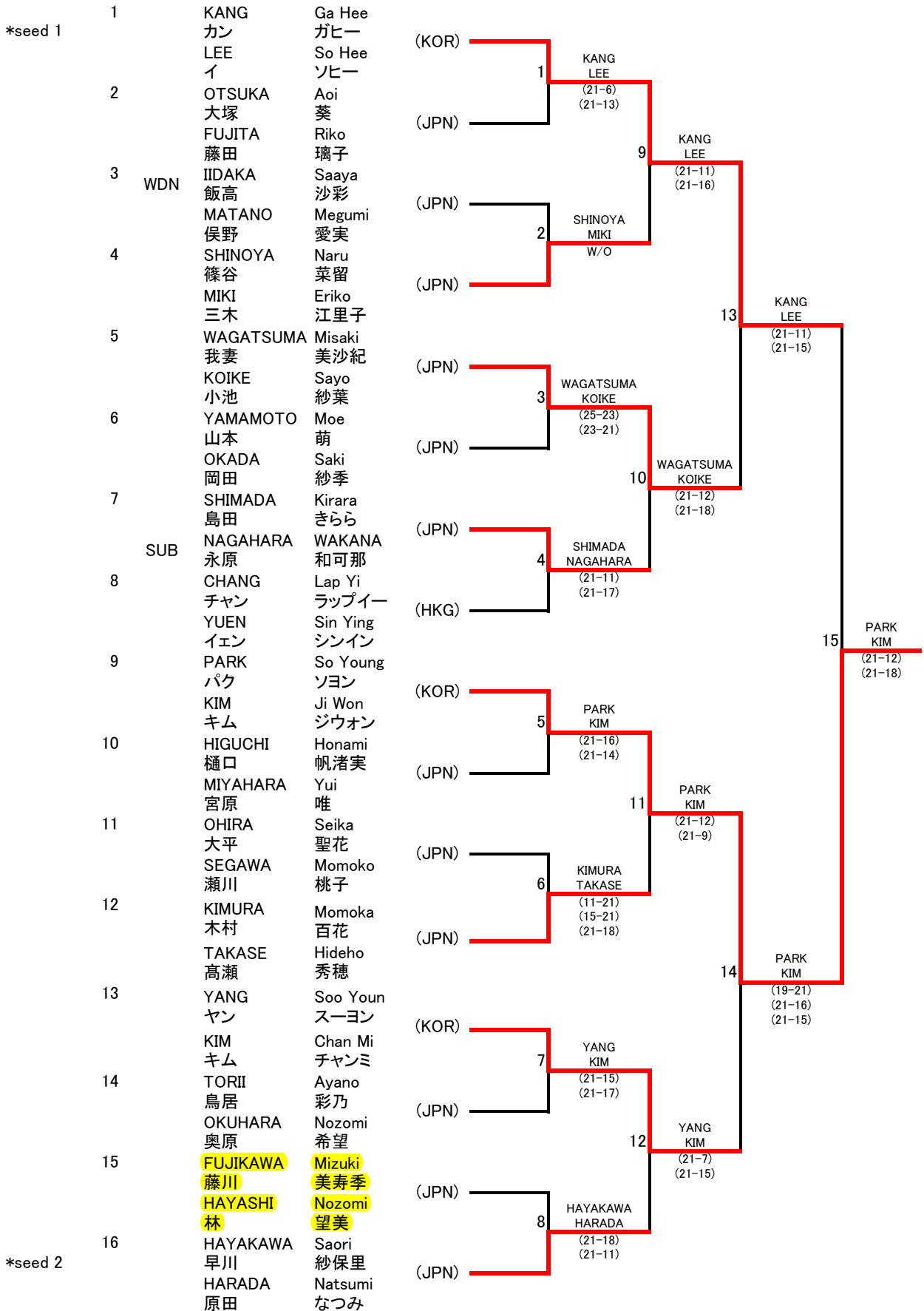

U15BS

Rank	Seed	Name	Country	Score
1	*seed 1	IGARASHI 五十嵐	(JPN)	1
2		LUO ルオ	(TPE)	2
3		THAMMASIN タンマシン	(THA)	9
4	Q1	ONODERA 小野寺	(JPN)	2
5		LEE リー	(HKG)	13
6	Q2	NISHI 西	(JPN)	3
7		MATSUMOTO 松本	(JPN)	10
8		PARK パク	(KOR)	4
9		LEE リー	(HKG)	15
10		HOKI 保木	(JPN)	5
11		YANG ヤン	(TPE)	11
12	Q3	TAMATE 玉手	(JPN)	6
13		LEE リー	(HKG)	14
14		NAKAZATO 中里	(JPN)	7
15	Q4	KOGA 古賀	(JPN)	12
16	*seed 2	CHOI チェ	(KOR)	8

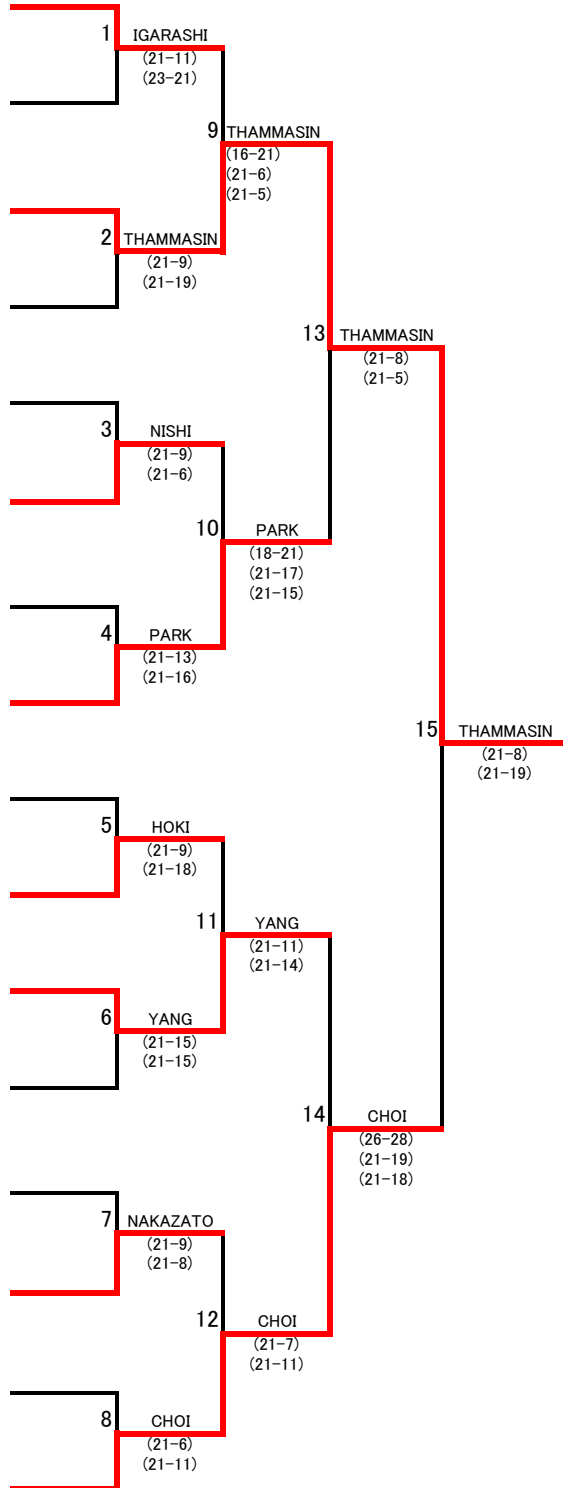

U15GS

Rank	Seed	Name	Country	Score
1	*seed 1	LEE イ	(KOR)	Sun Min スンミン
2	Q1	HAMAKITA 濱北	(JPN)	Momo もも
3		MORI 森	(JPN)	Mizuho みず穂
4		HOSHI 星	(JPN)	Chisato 千智
5		OGAWA 小川	(JPN)	Yuka 由香
6	Q4	HONGCHOOKEAT ホングチューケアット	(THA)	Soikhaimuk ソイクハイムック
7		NAKAI 仲井	(JPN)	Yukino 由希乃
8		HUANG ファン	(HKG)	Wun Yan ウンヤン
9		CHAE チェ	(KOR)	Yoo Jung ユージュン
10		ARAKI 荒木	(JPN)	Akane 茜羽
11		CHIONG チョン	(HKG)	Hoi Yan ホイヤン
12		OHORI 大堀	(JPN)	Aya 彩
13		KHIAOROTPHAI クヒアオロトファイ	(THA)	Piyathida ピヤットヒダ
14	Q2	NAGAHARA 永原	(JPN)	Wakana 和可那
15	Q3	NAKAMURA 中村	(JPN)	Yuki 幸
16	*seed 2	SAKURAMOTO 櫻本	(JPN)	Ayako 絢子

Rank	Score	Name	Country
1	(21-14) (21-16)	HAMAKITA	(JPN)
2	(21-15) (21-14)	HOSHI	(JPN)
3	(19-21) (21-9) (21-15)	HONGCHOOKEAT	(THA)
4	(21-16) (12-21) (11-21)	HONGCHOOKEAT	(THA)
5	(21-18) (21-18)	HONGCHOOKEAT	(THA)
6	(21-11) (19-21) (21-14)	NAKAI	(JPN)
7	(14-21) (21-18) (21-13)	CHAE	(KOR)
8	(22-20) (21-13)	OHORI	(JPN)
9	(21-12) (21-11)	OHORI	(JPN)
10	(21-12) (23-21)	KHIAOROTPHAI	(THA)
11	(21-17) (21-19)	KHIAOROTPHAI	(THA)
12	(21-16) (21-13)	SAKURAMOTO	(JPN)
13	(22-20) (21-16)	KHIAOROTPHAI	(THA)
14	(21-13) (21-11)	HONGCHOOKEAT	(THA)

U15BD

Seed	Rank	Category	Name	Country	Score
*seed 1	1		HOKI Takuro 保木 卓朗	(JPN)	
	2		NAKAZATO Yuki 中里 裕貴	(JPN)	
	3	Q2	YAMAGUCHI Yusuke 山口 友輔	(JPN)	
	4		HORI Taichi 堀 太一	(JPN)	
	5		KOMORIZONO Ryuhei 小森園 隆平	(JPN)	
	6		YAMASHITA Takashi 山下 京	(JPN)	
	7		PONG Lap Yan Larry ポン ラップヤン・ラリー	(HKG)	
	8		LO Justin Kevin Hei ロー ジャスティン・ケビン・ヘイ	(HKG)	
	9		YANG Yi Xiang ヤン イーシャン	(TPE)	
	10		LUO Kuan Siang ルオ クアンシヤン	(JPN)	
	11		KOGA Minoru 古賀 穂	(JPN)	
	12		NISHI Yutaka 西 豊	(JPN)	
	13	Q3	USHIO Yuki 牛尾 裕貴	(JPN)	
	14		NAKAYAMA Daisuke 中山 大輔	(JPN)	
	15		IGARASHI Yu 五十嵐 優	(JPN)	
	16		MATSUMOTO Kohei 松本 康平	(JPN)	
*seed 2	17	Q4	SHIMA Takashi 嶋 崇	(JPN)	
	18		NISIJIMA Shintaro 西嶋 真太郎	(HKG)	
	19		LEE Cheuk Yiu リー チュックユー	(HKG)	
	20		LEE Ting Fung リー ティンフン	(JPN)	
	21		KONDO Shunya 近藤 峻矢	(JPN)	
	22		SHIMONO Hashiru 下農 走	(JPN)	
	23	Q1	NAKAMINE Shintaro 中峰 信太郎	(JPN)	
	24		NAKAJIMA Kenta 中島 健汰	(TPE)	
	25		WU Yuan Jheng ウー ユアンジェン	(HKG)	
	26		LI Jia Han リー ジャーハン	(JPN)	
	27	SUB	LEE Chak Wai リー チャックワイ	(JPN)	
	28		TAMATE Katsuki 玉手 勝輝	(JPN)	
	29		YAMAKAKU Taisuke 山角 太佑	(JPN)	
	30		KOBAYASHI Yugo 小林 優吾	(KOR)	
	31		CHOI Sol Kyu チェ ソルキュ	(KOR)	
	32		PARK Se Woong パク セウン	(KOR)	

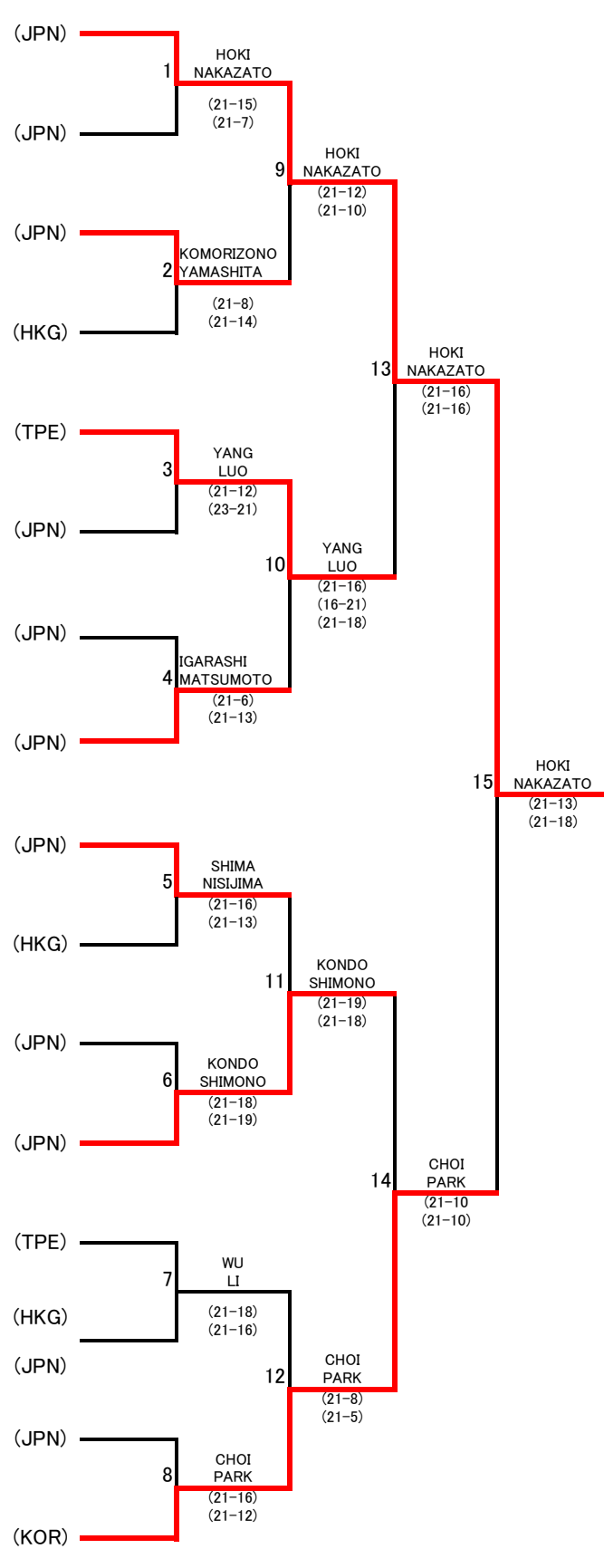

U15GD

